

Basics of asphalt-roofing layout. The author overhangs the asphalt shingles 1 in. on both the rake and the eaves. Before nailing down any shingles, he strikes two

vertical bond lines and a series of horizontal lines to ensure that the tabs and the courses will line up neatly. After the layout is finished, nailing on the shingles is a breeze.

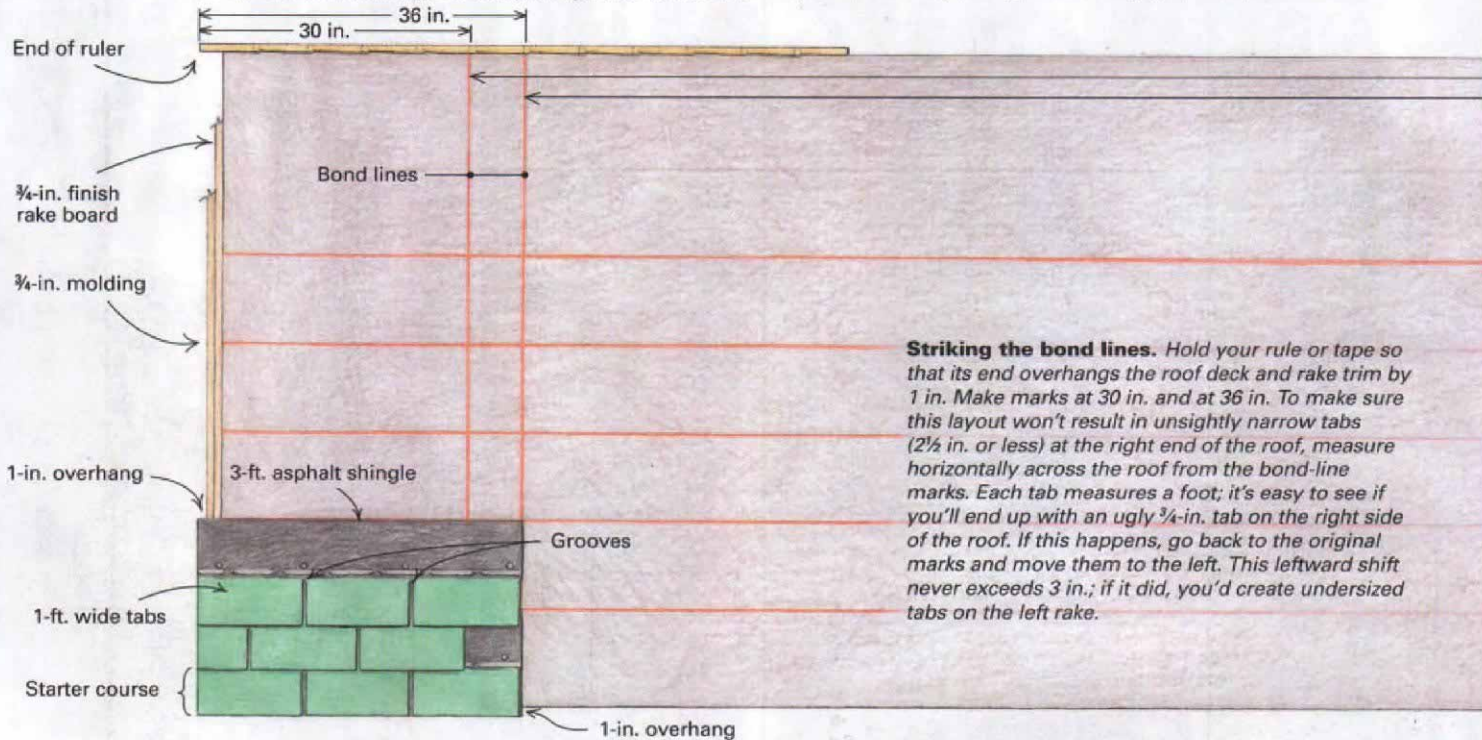

Striking the bond lines. Hold your rule or tape so that its end overhangs the roof deck and rake trim by 1 in. Make marks at 30 in. and at 36 in. To make sure this layout won't result in unsightly narrow tabs (2½ in. or less) at the right end of the roof, measure horizontally across the roof from the bond-line marks. Each tab measures a foot; it's easy to see if you'll end up with an ugly ¾-in. tab on the right side of the roof. If this happens, go back to the original marks and move them to the left. This leftward shift never exceeds 3 in.; if it did, you'd create undersized tabs on the left rake.

Establishing the overhang. Contrary to manufacturers' recommendations, the author overhangs roof shingles

1 in. on both rakes and eaves. Longer overhangs accounts for possible discrepancies in the straightness of the trim.

Laying Out Three-Tab Shingles

Spend a little time measuring and striking lines, and the rest is fairly easy

by John Carroll

Many roofers take pride in the fact that they can shingle a house without the benefit of measured lines. It can't be denied that such people install leak-proof roofs that look pretty good from the ground. Unfortunately, their eyeballed roofs often have wavy, inconsistent courses; and when viewed from atop the house, they look simply unprofessional. When I finish a roof, I enjoy looking at straight courses, and I don't begrudge myself the half-hour or so it took to measure and strike lines. More than that, I'm convinced that I recover the time invested in laying out the roof as I nail down shingle after shingle without worrying about the courses getting wavy or crooked.

For the sake of simplicity, I'll limit my discussion to the ubiquitous three-tab asphalt roof shingle, scorned by aesthetes but found on houses from the Carolinas to California.



Running; straight courses. The author aligns shingles using a gauged roofing hammer and vertical bond lines.

On a rectangular roof without dormers, valleys or other obstructions, there are three basic layout steps: establishing the overhang, striking the bond lines and striking the horizontal lines.

Establishing the shingle overhang—Before shingling a roof, it is essential to know how far the shingles will overhang the bottom (or eaves) and sides (or rakes) of the roof deck. Ideally, all trim has been installed along the roof edges, and if used, metal drip edge is also in place. In these cases I leave a 1-in. overhang along the eaves and the rakes of the roof (drawing above). Most shingle manufacturers recommend a ¼-in. to ¾-in. overhang, presumably to reduce the chance of the wind snagging the edge of the roof.

Unfortunately, eaves and rakes (especially those on older houses) often diverge more than

If either of these measurements is slightly more than a full-foot increment (2½ in. or less), move bond lines to the left 1 in. to 3 in.

Striking the horizontal lines. To mark the horizontal line for your starter course, hold your rule or tape so that it overhangs the drip edge by 1 in. Make a mark at 12 in. on both ends of the roof deck and strike a connecting line. The top of the starter-course shingles will be laid to this line. Then measure in 10-in. increments up the roof deck, starting from your starter-course line. These lines show where to lay the top edge of every other course. Intermediate courses are lined up using a gauged roofing hammer.

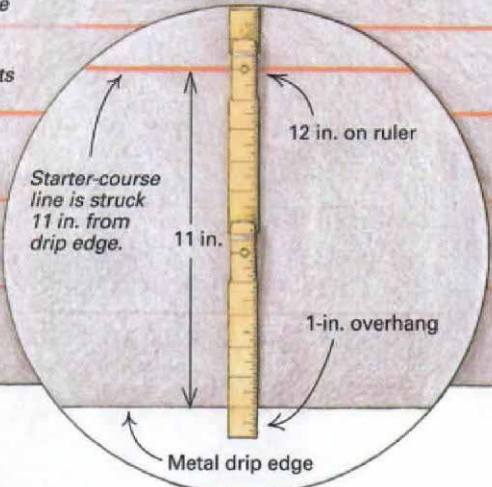

Lines are struck in 10-in. increments, measured from starter-course line.

Starter-course line

Metal drip edge

Reestablishing the starter course

When shingling around a dormer or other obstruction on the roof deck that interrupts the starter course, run shingles to a point past the obstruction, then strike a new set of bond lines using the end of a shingle as a reference point. Measure from the shingle over to the right-side rake and transcribe this measurement (X) to a point lower on the roof. Strike a line to connect the point and the shingle edge above. Then strike another line 6 in. to the left. Remember that the top shingle of the starter course always starts on the right-hand bond line.

Nail the first course above the obstruction high on the shingle, within 2 in. of the top, so that the shingle course below it can slip underneath.

X

X

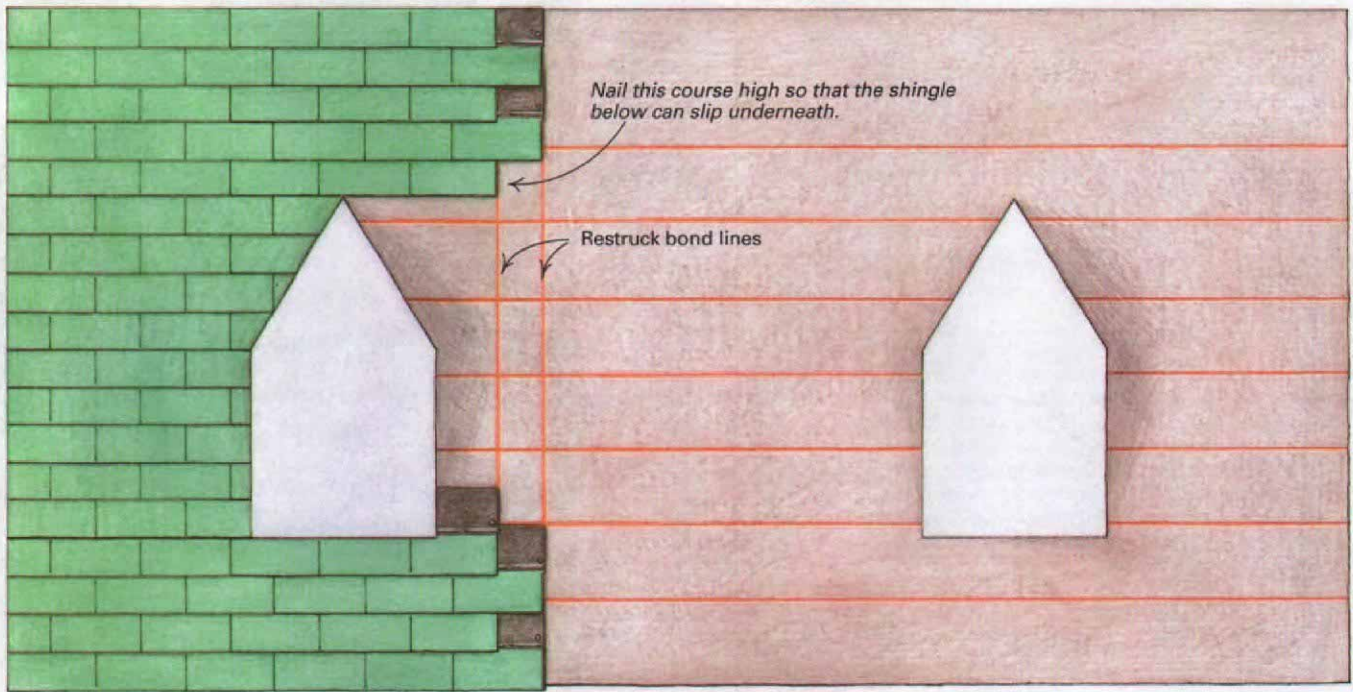

Shingling around dormers. When dormers interrupt the roof plane, run shingles past the dormer, above and below. Strike bond lines between the top and bottom sections, first along the outside edge of one course, then along

the outside edge of the next course offset by 6 in. The next row to the right of the bond lines goes from the bottom of the roof to the peak, leaving an unroofed area to the right of the dormer, which can be filled now or later.

$\frac{3}{8}$ in. from a straight line. To compensate for irregularities in the straightness of rake boards and fascia boards, I've found that a 1-in. overhang allows me to work proficiently and provides for a straight, secure roof. I've never had a problem with shingles blowing off.

If I install the shingles before the roof trim is complete, I need to know how far the trim pieces and the drip edge will extend the roof deck, and I allow for that extension. For example, if a 1x6 rake board and a piece of molding, totaling 1½ in., will be added to the existing sheathing, I know I should let the shingles overhang the sheathing by 2½ in. to get a final overhang of 1 in. Because shingles are easy to cut, it is better to err on the side of too much as opposed to too little overhang. If need be, I can go back later and trim the overhanging shingles.

Three-tab asphalt shingles are 3 ft. long. They have three 1-ft. tabs with grooves cut between them in the part of the shingle that is exposed to the weather. The grooves both break up the otherwise solid appearance of the shingle (possibly making them look more like wood shingles or slate shingles) and provide a channel for water to run off the roof. It is important that the grooves of every other course line up over one another and that the grooves of the course in between fall in the middle of the tab of the shingle above and below.

Like most right-handed roofers, I usually start shingling on the left side of the roof. This enables me to work from left to right, positioning shin-

gles with my left hand and nailing them off with my right hand.

Striking the bond lines—To keep the grooves straight and the shingles properly bonded or centered over the tabs just below, the shingles are laid to follow two vertical chalklines, called bond lines, struck near the left rake of the roof (drawing p. 50). Bond lines are always struck 6 in. apart—half the width of a tab; this aligns the 1-ft. tabs of alternate vertical shingle rows.

If I need to leave, say, a 2½-in. rake overhang, I extend my ruler exactly 2½ in. past the roof deck and make marks at 30 in. and at 36 in. This is a preliminary measurement. To make sure this layout won't result in unsightly narrow tabs (2½ in. or less) at the opposite edge of the roof, I measure across the roof from these marks. Each foot represents a tab, and it's easy to see if I'll end up with an ugly $\frac{3}{4}$ -in. tab on the right side of the roof. If this is the case, I go back to the original marks and move them to the left. This leftward shift never exceeds 3 in.; if it did I would be creating undersized tabs on the left rake.

When I'm satisfied that I won't end up with little tabs at either end of the roof, I make identical measurements at the top and the bottom of the roof along the left-hand side. Then I strike a vertical, parallel bond line at both the 30-in. and 36-in. marks.

When I'm ready to install the shingles, I begin each horizontal course on a bond line, alternating between the two bond lines. But before I can

nail on any shingles, I also have to measure and strike horizontal lines

Striking the horizontal lines—Standard shingles are 1 ft. high. To lay out the first course, called the starter course, I need to know the overhang at the roof eaves. If all of the trim and drip edge has been installed, I hold my folding rule so that it extends 1 in. past the drip edge, and I make a mark at 1 ft. I make the same mark at the other end of the roof and then strike a chalkline across the roof deck (top drawing, p. 51).

Shingle exposure is the height of the shingle that will be exposed to the weather. In most cases, the exposure of three-tab asphalt shingles is 5 in. Shingles are 1 ft. high, so each successive shingle will overlap the one below it by 7 in.

It's not necessary to strike lines every 5 in.; in fact, I always strike lines in increments of 10 in. There's a reason for this, which I'll explain shortly. When I mark my horizontal lines, I place the end of my rule at the starter-course line, and then I make marks every 10 in. If I'm working alone, I often strike lines in increments of 20 in. or 30 in. The most important thing to remember is that all lines are measured off the starter-course line rather than off the drip edge.

Running the shingles—After striking lines, I start nailing shingles where the bond lines intersect the starter-course line. The starter course is always nailed on the roof upside down. The next row of shingles is nailed right-side up, directly on

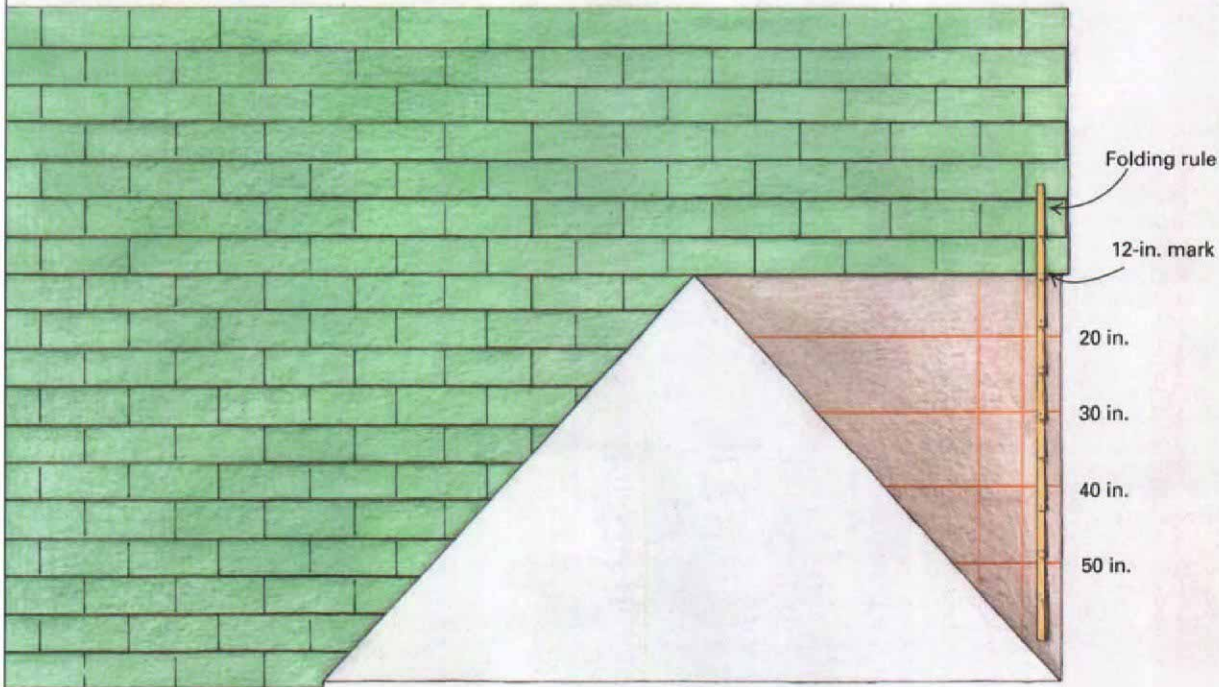

If there's no starter course. On the far side of an intersecting roof or dormer, run top shingles to the right rake, then transcribe measurements and strike bond lines. Measure down by extending a folding rule so that the 12-in. mark is on the bottom of the first shingle in the top section.

The shingle is 12 in. high, so the zero point of the ruler is even with the top of that shingle. Mark every 10 in. to the bottom of the roof. The bond returns to its starting point every 10 in., so every shingle that hits a 10-in. mark lines up with the tabs of first shingle in the top section.

top of the starter course. The reason for this is to cover the metal drip edge that would otherwise be exposed to the weather by the grooves in the right-side up second course.

I always begin the upside-down starter course on the left-hand bond line. The next course goes directly on top of the first and begins on the right-hand bond line. Because the lines above the starter course are marked in increments of 10 in., every other shingle hits a horizontal line, and every shingle that hits a horizontal line also hits a right-hand bond line (including the exposed starter). I follow this routine religiously because the consistency is very useful on complex roofs, as we shall see.

Horizontal, diagonal or vertical shingling?

A neat, professional roof can be installed by running shingles horizontally, diagonally or straight up the roof. Running each course horizontally across the roof is the simplest method and is usually preferred by amateurs. Running the shingles diagonally across the roof so that they look sort of like a staircase is often recommended by shingle manufacturers because of the possibility that the shingle color might vary from bundle to bundle. The thought is that the variegations will be less noticeable if the different colors are run diagonally rather than straight up or straight across a roof.

Like many roofers, however, I prefer to run vertical rows straight up the roof. I do this for two reasons. First of all, I find it less strenuous be-

cause it does not require as much reaching and moving about. Secondly, on hot days I find it to be more comfortable because I'm sitting or kneeling on shingles I've just laid. These are a lot cooler than those that have had a chance to soak up the sun. I've never had a complaint about the blend of colors on any of the roofs I've installed. I have noticed, though, that an off-color bundle looks equally bad whether it runs straight up the roof or diagonally.

For those who choose to run shingles vertically, here is one caution: You have to leave the far right-hand nail out of every other course (the one that hits the right-hand bond line). This allows the shingles in the next row to slip into place. I always use four nails to the shingle in the recommended pattern. To do this I have to lift the tab of every other shingle in the preceding row.

Using a gauged hammer—As mentioned previously, I often strike horizontal lines every 20 in. or 30 in. To keep in-between courses straight, I use an Estwing gauged roofing hammer (Estwing Mfg. Co., 2647 8th St., Rockford, Ill. 61109-1190; 815-397-9521). This hatchetlike hammer has a steel knob bolted through its blade exactly 5 in. from the face of the hammer head (photo p. 50). After following the struck horizontal line with one shingle, I line up the next three courses (if I'm using 20-in. increments) with my hammer. The steel knob, or gauge, hooks onto the bottom of the shingle in the previous row, and the bottom of the next shingle sits on the hammer head.

Laying out complicated roofs—So far I've limited this discussion to a straight, rectangular section of roof. Roof planes come in a variety of shapes and sizes, however, and they are apt to be intersected by chimneys, dormers and adjoining roofs. Shingling around these obstructions complicates the job, but by adhering to a consistent 10-in. layout scheme and using a few simple techniques, it's easy to keep the courses straight and correctly bonded.

To go around a pair of dormers (drawing facing page), I lay out the bond lines and the horizontal courses as previously described. Some of the horizontal lines are interrupted by the dormers and have to be measured and marked separately on each side of the dormers. When I start roofing, I run a row of shingles all the way up the left rake and work toward the right until I come to the left side of the first dormer. I continue to shingle the area below the dormer until I'm past the dormer. At this point I move back to the left side of the dormer, cut and fit shingles along the dormer wall, install flashing and weave the first valley created by the dormer's roof.

There is now a short row of shingles running from the top of the valley to the ridge of the main roof. I carry these courses to the right until they line up with the courses below. To permit the courses that will be installed below these shingles to slide into place, I nail the first course high on the shingle, within 2 in. of the top edge. I strike bond lines between the top and bottom sections, holding the string first along the outside edge of

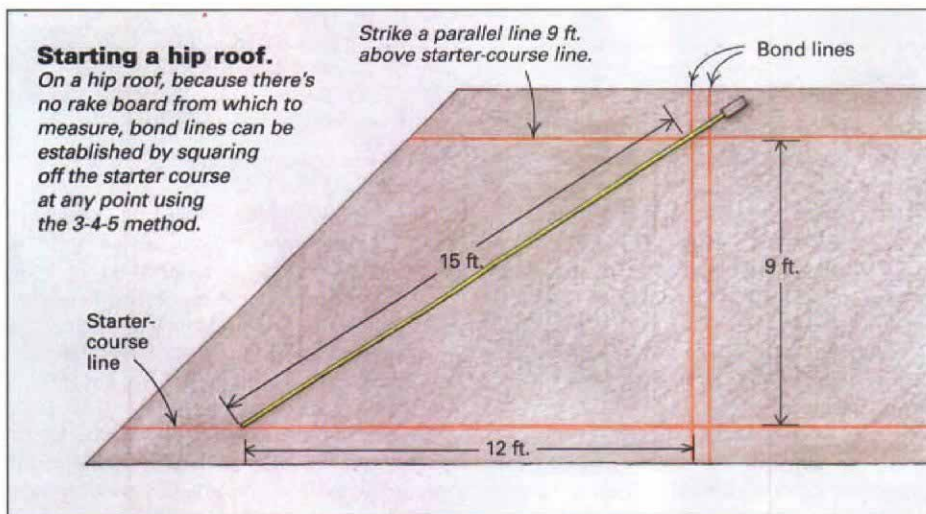
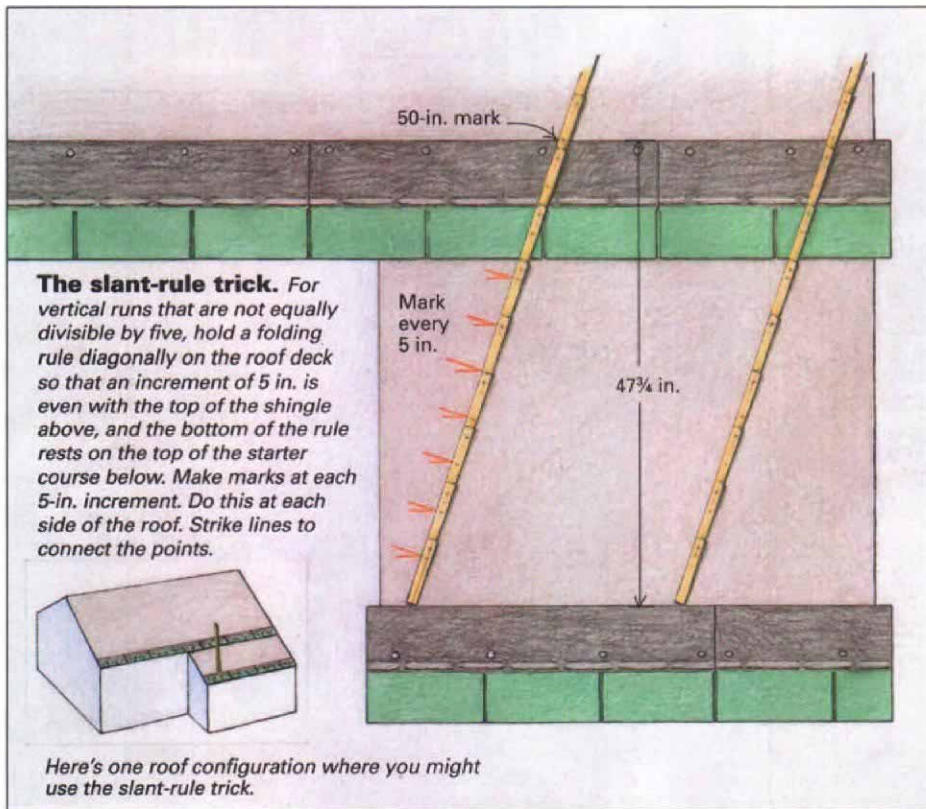

one course, then along the outside edge of the next course that is offset by 6 in. The next row of shingles goes from the bottom of the roof to the ridge, leaving an unroofed area to the right of the dormer. This area can be filled in now or later, according to the temperament of the roofer. I like to complete this section as I go along.

This process is repeated around the second dormer; I shingle past the dormer at the top and the bottom, strike bonds lines through and fill in.

Reestablishing the starter course—When large dormers or intersecting roofs interrupt the bottom section of a roof plane, it is impossible to strike through (bottom drawing, p. 51). So after running shingles across the top of the roof, nail-

ing the first course high until I've cleared the entire obstruction, I measure the distance from the end of one of the right bond shingles to the right edge of the roof deck. I transcribe this measurement to the bottom of the roof, make another mark 6 in. to the left and strike bond lines. Then I measure and strike my 10-in. horizontal lines.

I'm now ready to run shingles from the bottom of the roof up the bond lines. But the question is, on which bond line do I start? If I pick the wrong one, I'll end up with adjoining courses where all the tabs line up rather than being offset by 6 in.—a roofing abomination. Fortunately, I've struck lines every 10 in., and I've started, as I always do, with the exposed starter shingle on the right bond line. I know every shingle that hits a hori-

zontal line also hits a right bond line. I put the inverted shingle of the starter course on the left bond line and cover it with the exposed starter course on the right bond line. As I run up the bond lines, I notice that every shingle that hits a horizontal line also hits a right bond line. I know the bond will work out perfectly.

When there's no starter course—Sometimes there's no starter course on the far side of an intersecting roof or dormer (drawing p. 53). If so, after I run the top section of shingles over to the rake, I measure and strike bonds in the usual manner. Let's say that I have not struck any horizontal lines in the triangular section created by the intersecting roof. How would I measure down, and what bond line would I start on? To measure down, I extend my folding rule and lay it on the roof deck so that the 12-in. mark is on the bottom of the first shingle in the top section. The shingle is 12-in. high, so this puts the zero point of the rule even with the top of that shingle. Now I mark at every multiple of 10, i. e., 20 in., 30 in., etc., until I get to the bottom of the triangular section of roof. Because the bond returns to its starting point every 10 in. (or every other course), I know that the grooves of every course that hits a 10-in. multiple will line up with the grooves of the first shingle in the top section. I make sure it does.

Starting a hip roof—Sometimes it's not practical to start roofs on the left side. Hip roofs or roofs with obstructions on the left side should be started toward the center of the roof deck. On a hip roof you can't measure from the rake to establish the bond lines. They must be squared up at some point along the starter course using the 3-4-5 method (bottom drawing, left). After striking the starter-course line, I mark a point, measure 12 ft. along the line from that point and make another mark. I strike a parallel line 9 ft. above the starter course, pull a tape measure diagonally from the 12-ft. mark on the starter course until the 15-ft. mark on the tape intersects the upper chalkline, and I make a mark. Stretching a chalkline from my first mark on the starter course to the mark above to the ridge of the roof, I strike my first bond line. I strike a second line 6 in. to the right. Then I can run all of my shingles from left to right, then come back and fill in the hip.

The slant-rule trick—Occasionally it's necessary to fit shingle courses into a space that's not divisible by 5 in. (top drawing, left). If the run of a section of roof from starter course to intersecting roof is, say, 47 $\frac{3}{4}$ in., some roofers might run nine courses at 5 in. and the last course at 2 $\frac{3}{4}$ in. A better way to set up the courses is to divide the 47 $\frac{3}{4}$ in. into 10 equal courses. Nail on your first two starter courses—inverted and right-side up. Then put your tape on the starter-course line and run the tape diagonally across the roof until you come to a 5-in. increment—in the example above, 50 in. Make a mark at each 5-in. increment. Do this on both sides of the roof and strike lines between each mark. □

John Carroll is a builder in Durham, N. C.